

# Autmix®



**COMPACT MIXERS CT**  
SYNCHRONISM SERIES

**CT(F)**

# COMPACT MIXERS CT

## SYNCHRONISM CT(F)

### MOTOR

- P** 0.55 to 2.2 kW    **Φ** Three-phase
- V** 230 - 460 V       IEC: IE3  
NEMA: High Premium

### MANUFACTURING MATERIALS

- Carbon steel
- AISI 304
- AISI 316
- Super duplex
- Duplex

### OUTPUT SPEED

(50 Hz) 750, 1 000, 1 500 RPM  
(60 Hz) 900, 1200, 1800 RPM

### SHAFT-HEAD COUPLING

- Hollow Shaft - Keyway
- Solid Shaft - Coupling
- Hollow shaft - Shrink disk



**IMPELLER DIAMETER**  
Up to 200 mm

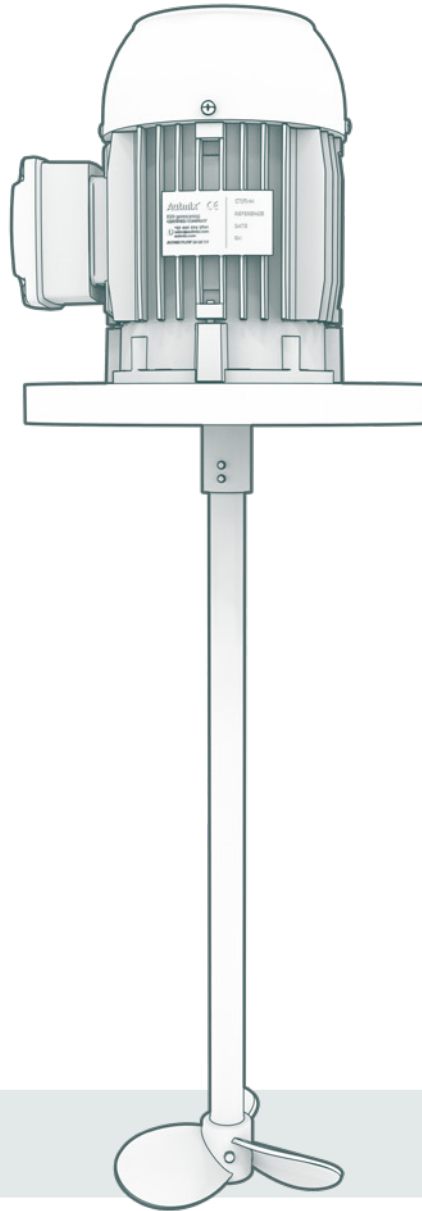

### MOUNTING OPTIONS

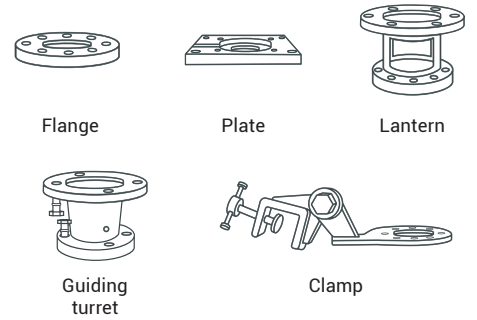

### SEALING OPTIONS

- Cartridge seals
- Cable gland
- Double mechanical seal
- Simple mechanical seal

### SHAFT LENGTH

1 500  
1 000  
500  
250  
mm

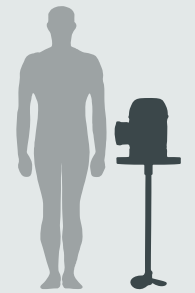

### SHAFT-IMPELLER COUPLING

- A) Bush welded to the shaft
- B) Lugs C) key-keyway

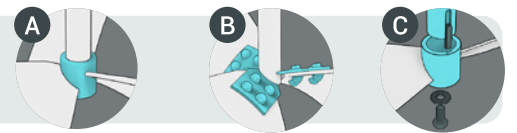

### COMPATIBLE IMPELLERS

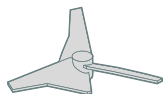

GAMMA



MARINE

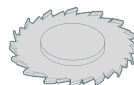

COWLES



RUSTHON



ROTOR STATOR

### RELATED INDUSTRIES



## COMPACT MIXERS CT SYNCHRONISM CT(F)

### REACTOR PRESENTATION

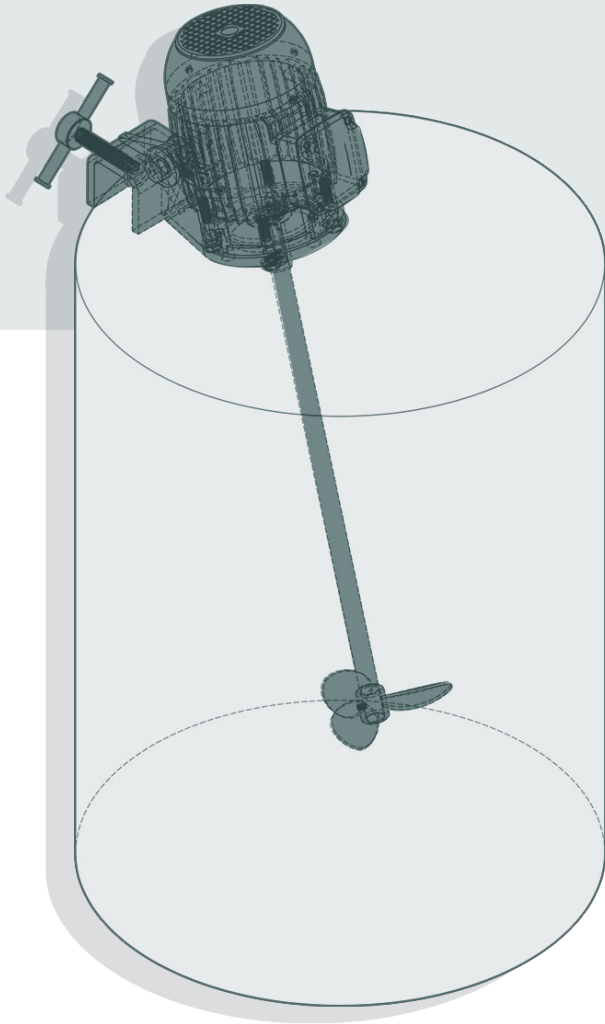

### REACTOR VOLUME

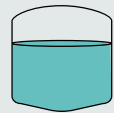

0.3 m<sup>3</sup> - 7 m<sup>3</sup>

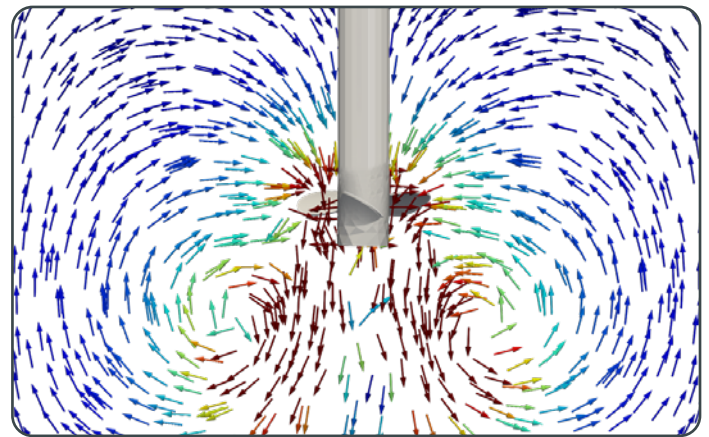
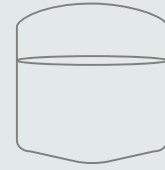

FLOW LINES | MARINE IMPELLER REPRESENTATION

### OPTIONAL FEATURES

- ATEX protection
- Stainless steel housing
- Food grade oil
- Food grade epoxy paint

### FINISHES AND COATINGS

- PTFE
- PVDF
- EPDM
- Halar
- Butyl rubber
- Natural rubber
- Ebonite
- Neoprene
- Fiberglass
- Sanitary polishing



### NEED HELP?

autmix.com  
Sales | sales@autmix.com  
Support | support@autmix.com

INTERNATIONAL COVERAGE  
24 / 7 SUPPORT



### MEXICO

+52 442 224 5621

### UNITED STATES

+1 972 955 0168

### SPAIN

+34 914 37 2618