

Autmix®

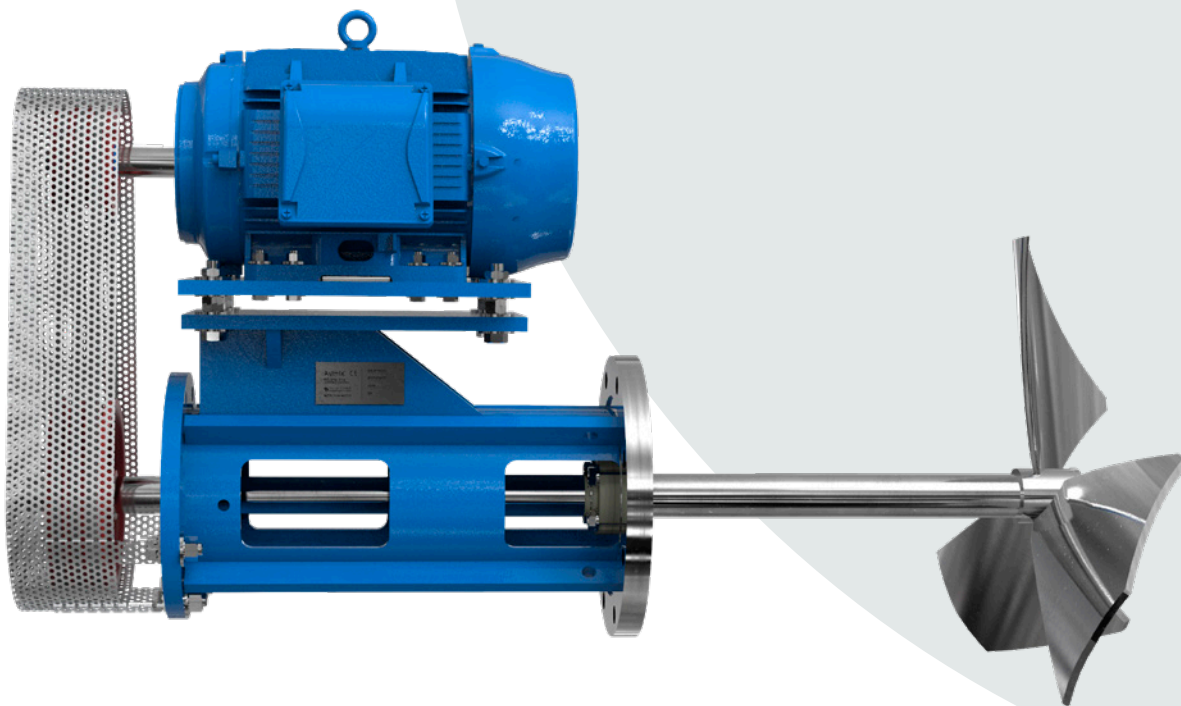

**HORIZONTAL AND BOTTOM
MIXERS ZB
BELT DRIVE**

ZB(P)

**HORIZONTAL AND BOTTOM MIXERS ZB
BELT DRIVE ZB(P)**

MOTOR

- P** 7.5 to 75 kW **φ** Three-phase
- V** 230 - 460 V  IEC: IE3
NEMA: High Premium

SHAFT-HEAD COUPLING

- Hollow Shaft - Keyway
- Solid Shaft - Coupling
- Hollow shaft - Shrink disk

MOUNTING OPTIONS

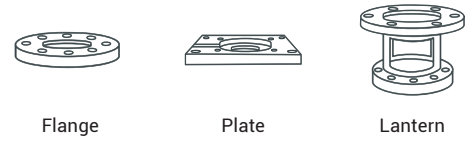

SEALING OPTIONS

- Cartridge seals
- Cable gland
- Double mechanical seals
- Simple mechanical seals
- Seals
- Hydraulic labyrinth

MANUFACTURING MATERIALS

- Carbon steel
- Duplex
- AISI 304
- Titanium
- AISI 316
- Hastelloy
- Super duplex
- Uranus B6

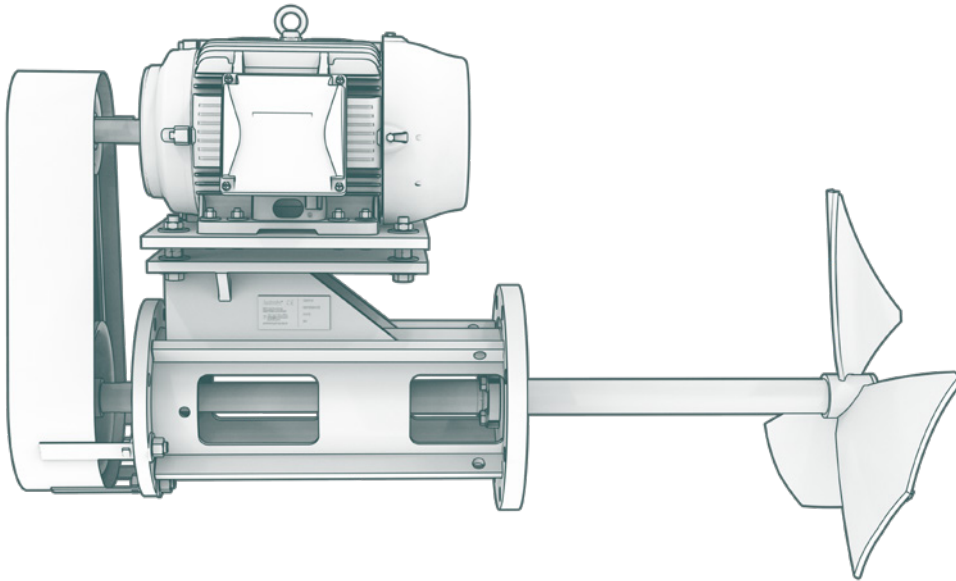

SHAFT LENGTH

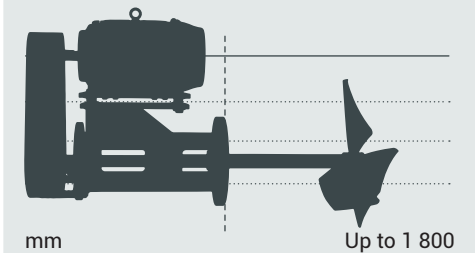

TRANSMISSION

- System by pulleys and belts



IMPELLER DIAMETER
200 - 500 mm

SHAFT-IMPELLER COUPLING

- A) Bushing welded to the shaft
- B) Oppressors C) Lugs
- D) key-keyway

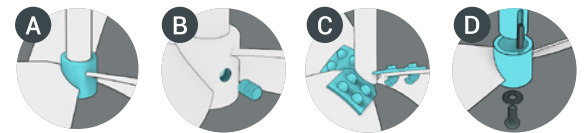

COMPATIBLE IMPELLERS

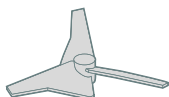

GAMMA

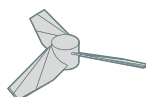

STOKES

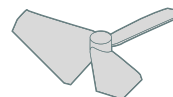

NABLA

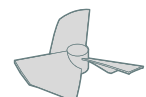

SABRE

RELATED INDUSTRIES



HORIZONTAL AND BOTTOM MIXERS ZB BELT DRIVE ZB(P)

REACTOR PRESENTATION

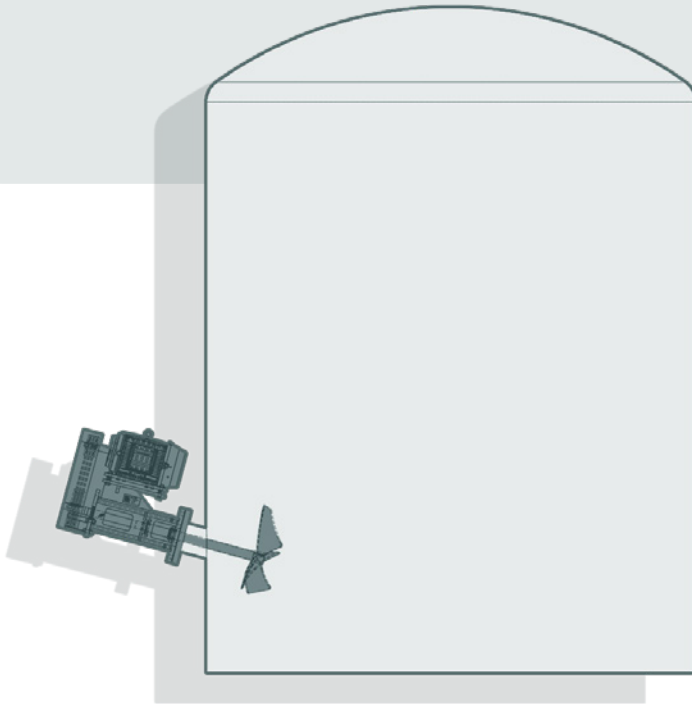

REACTOR VOLUME

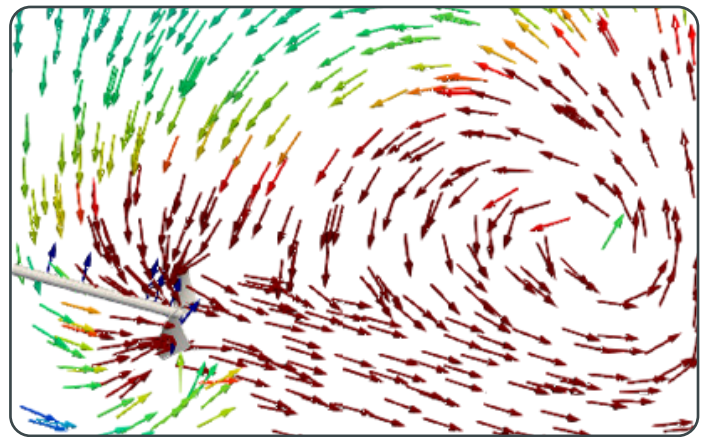
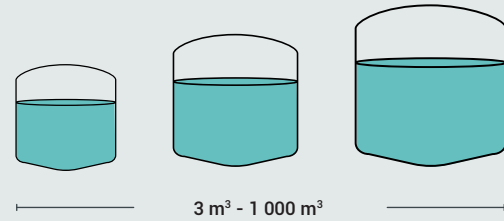

FLOW LINES | SABRE IMPELLER REPRESENTATION

FINISHES AND COATINGS

- PTFE
- PVDF
- EPDM
- Halar
- Butyl rubber
- Natural rubber
- Ebonite
- Neoprene
- Fiberglass
- Sanitary polishing

OPTIONAL FEATURES

- ATEX protection
- Stainless steel housing
- Food grade oil
- Food grade epoxy paint
- Full tank disassembly system
- Autonomous cooling system (thermosyphon)



NEED HELP?

autmix.com
Sales | sales@autmix.com
Support | support@autmix.com

INTERNATIONAL COVERAGE
24 / 7 SUPPORT



MEXICO

+52 442 224 5621

UNITED STATES

+1 972 955 0168

SPAIN

+34 914 37 2618