

Autmix®

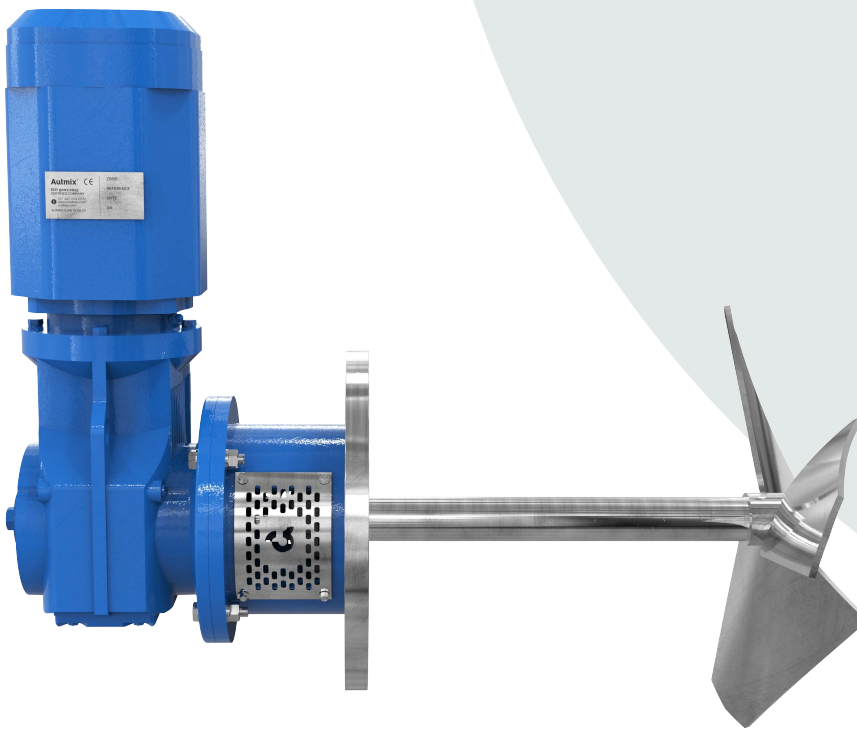

**HORIZONTAL AND BOTTOM
MIXERS ZB**
MOTOR AND GEAR UNIT

ZB(R)

HORIZONTAL AND BOTTOM MIXERS ZB MOTOR AND GEAR UNIT ZB(R)

MOTOR

- Ⓟ 3 to 75 kW
- Ⓢ Three-phase
- Ⓥ 230 - 460 V
- IEC: IE3
NEMA: High Premium

GEAR UNIT

- Coaxial
- Parallel shaft
- Conical gear

OUTPUT SPEED

100 - 300 RPM

MOUNTING OPTIONS

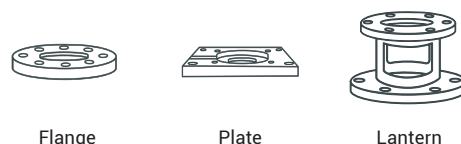

SEALING OPTIONS

- Cartridge seals
- Simple mechanical seals
- Cable gland
- Seals
- Double mechanical seals
- Hydraulic labyrinth

MANUFACTURING MATERIALS

- Carbon steel
- Duplex
- AISI 304
- Titanium
- AISI 316
- Hastelloy
- Super duplex
- Uranus B6

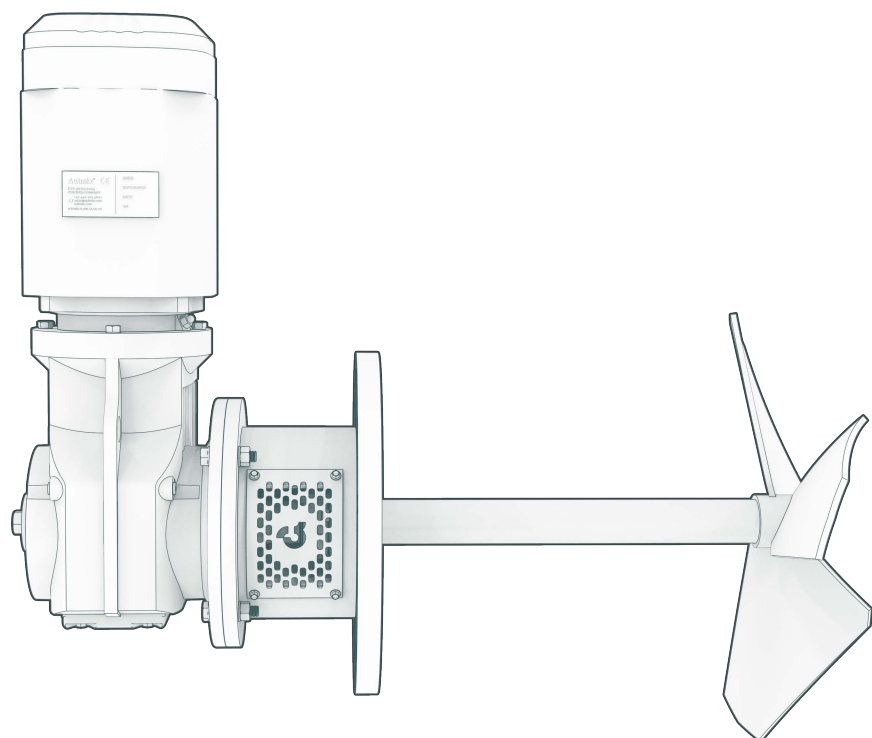

SHAFT LENGTH

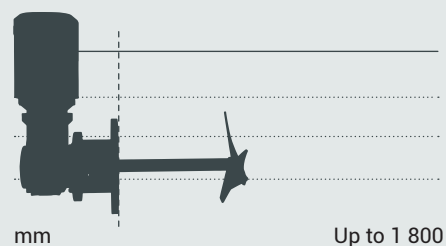

IMPELLER DIAMETER
200 - 1 200 mm

SHAFT-HEAD COUPLING

- Hollow Shaft - Keyway
- Solid Shaft - Coupling
- Hollow shaft - Shrink disk

SHAFT-IMPELLER COUPLING

- A) Bushing welded to the shaft
- B) Oppressors C) Lugs
- D) key-keyway

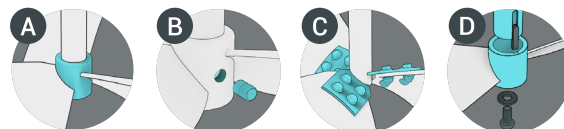

COMPATIBLE IMPELLERS

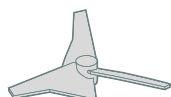

GAMMA

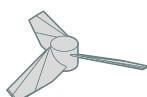

STOKES

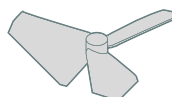

NABLA



SABRE

RELATED INDUSTRIES



HORIZONTAL AND BOTTOM MIXERS ZB MOTOR AND GEAR UNIT ZB(R)

REACTOR PRESENTATION

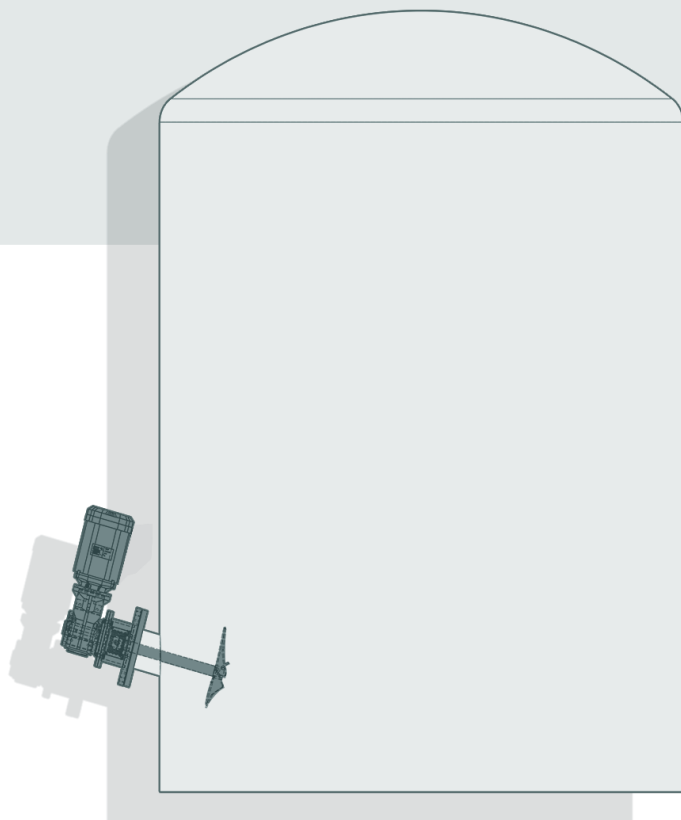

REACTOR VOLUME

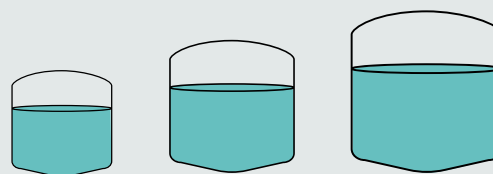

3 m³ - 1 000 m³

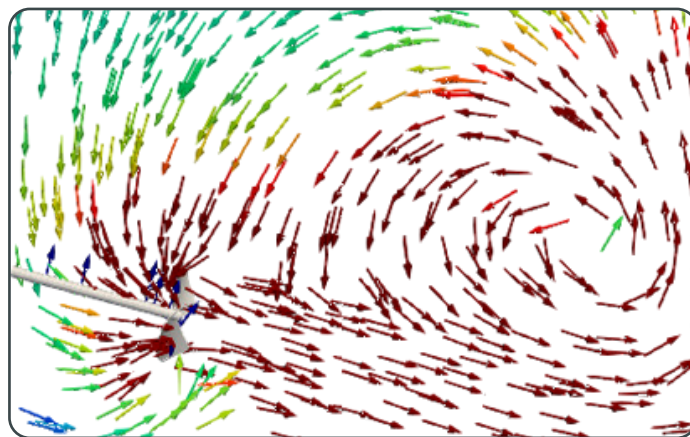

FLOW LINES | SABRE IMPELLER REPRESENTATION

OPTIONAL FEATURES

- ATEX protection
- Stainless steel housing
- Food grade oil
- Food grade epoxy paint
- Full tank disassembly system
- Autonomous cooling system (thermosyphon)



NEED HELP?

autmix.com
Sales | sales@autmix.com
Support | support@autmix.com

INTERNATIONAL COVERAGE
24 / 7 SUPPORT



MEXICO

+52 442 224 5621

UNITED STATES

+1 972 955 0168

SPAIN

+34 914 37 2618